

AMS[®]
Analitica
Air Monitoring Systems

ENVORINMENTAL **MONITORING**
2017

600/AFPM1001K

High volume sampler for sampling of PM10 particles with 1.27 m³-minute suction flow in accordance with norm UNI-EN 12341 (reference sampler) and with US EPA CFR 40 part 50.11

- Can be utilised with multi-stage inertial impactors
- Volumetric flow control in accordance with ISO-5167 requirements
- Total management of sampling phases by Microprocessor with control and visualization of standard deviation
- Connection with weather sensors for the detection of speed and wind direction for sector sampling (sensors not included)
- Remote GSM/GPRS management (Optional)
- External structure entirely in non-corrosive anodized aluminium
- Atmospheric temperature and barometric pressure detection
- Flow indicator: Digital by means of circuit board
- Programming: cyclic by means of circuit board
- Backlit HD graphics Plasma display
- Two-way RS 232 and USB port
- USB port for data transfer
- Automatic Re-Start in the event of current loss, with memorization of sampling periods and stop time display
- Flow control check by graphics display



The new high volume Air Flow PM10-HVS sampler line equipment perfectly complies with UNI-EN 12341 norm requirements for the respective sampling of PM-10 particles. It is equipped with an electronic flow control with a Venturi tube system in compliant with ISO 5167 requirements with differential pressure devices and for the detection of pressure itself on 4 points per sector, offering the user maximised accuracy for reliable results.

The new PM 10 dust particle impactor splitting were constructed in full compliance with requirements published in reference methods. When used with the aid of simple adapter kits, they can be replaced between one sampler and another for simple, versatile use. All sampling phase settings are electronically programmed.

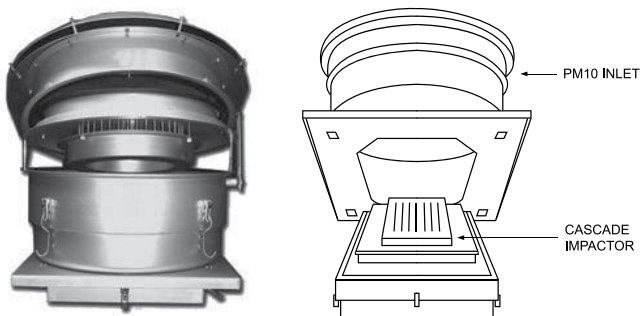

Samplings can be set by time, volume, cyclical sampling, from quadrant sector sampling. All detected data are stored in the memory and transferred to a PC or to an optional local printer with RS and USB ports, with the possibility of remote GSM/GPRS control (optional).

Thanks to new electronic support, it is possible to view all reported data at set values, sampling levels exceeding flow control chart patterns to ensure proper sampling development. It is possible to view the following data on the display:

- Set sampling time
- Remaining sampling time
- Atmospheric temperature
- Cabin temperature
- Atmospheric barometric pressure
- Sampling flow rate
- Sampling volume
- Standardized sampling volume
- Sampling irregularities
- Wind speed (with installed sensor)
- Wind direction (with installed sensor)
- Sampling summary data (max. 25 tests)

It is also possible to store in the memory a series of sampling settings related to standard or further monitored sites. High resolution atmospheric pressure, atmospheric temperature, sampling flow rate and standard deviation on sampling flow graphics can also be viewed on the display

Multi-stage impactor for EN-12341 reference preselector

Multi-stage impactor for EN-12341 reference preselector. It is possible to insert a series of cascade impactors in the PM10 HVS with preselector with reference cited in norm UNI-EN 12341 and US EPA CFR 40, Part 50.11, Appendix B. These impactors can be used to determine the division of different particle sizes of sampled particles.

Various options allow for the sampling in the same flow conditions provided for in current norms in effect.

This option offers a further guarantee if compared to other samplers which have not been mentioned in reference.

This distribution by differentiation of the aerodynamic diameter, different from the aerodynamic geometry, able to identify the type of trajectory which particles take inside the suction flow related to the three main aerodynamic factors of the particles themselves: dimension, shape and density. Three available models for use with 1.27m3 per minute suction flow are: 4 stages, 5 stages and single stage for PM-2.5 particles.

The impactors are constructed in anodised aluminium able to stand up to the most severe atmospheric conditions. A Teflon coated version is also available upon request. Impactors from 2 to 5 are arranged with 10 parallel slits. Impactor 1 has 9 slits.

The impactor is mounted directly on the upper part of the 20x25 filter holder and the membranes are made in fibreglass to facilitate particle retention. Different particle size fractions can be sampled modifying the sampling flow, reducing by 50% and using the same inertial impact supports. The following chart illustrates the various divisible particle size fractions.

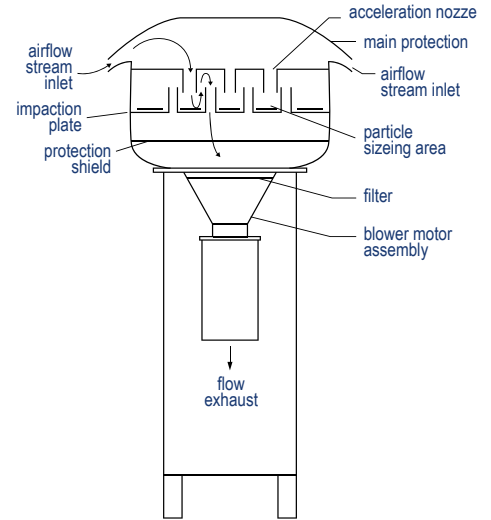

Particle Cut Size (Micron Cut-Off) with Efficiency at 50% per spherical particles with uniform mass carried out at 25°C and 1013mBar		
Stage number	1,27m3/min.-40 Cfm	0,63m3/min.- 20 Cfm
PM10-HVS	10	==
1	7,2	10,2
2	3,0	4,2
3	1,5	2,1
4	0,95	1,4
5	0,49	0,73
Final filter	0,0	0,0

Operating principle

Dispersed airborne particles enter into the high volume cascade impact system by means of the parallel slits positioned on the first impactor. Particles with dimensions exceeding the impactor cut are kept in the first filter of the impactor itself. Air flow then passes through the slits on the filter and the particles accelerate toward the second impactor which withholds the larger particles and allows smaller ones to continue on with the same procedure and so on for the remaining impact layers.

The width of the slits is the same for every impactor but become narrower the further the stage, allowing the smaller particles to remain trapped in one of the stages on the relative filters. After the last stage, the remaining particles impact on the final filter. The impactor membranes and final membrane are weighed to determine particle distribution. PM-HVS airflow samplers can also be installed on surfaces which are not perfectly smooth thanks to their adaptable, ball-joint base structure in slip-proof rubber.



Adapter kit

The true novelty of this device is its ability to interchange preselectors thanks to adapter kits. These supports allow for easy adaptability and rapid re-attachment to the sampler itself. The accurate flow control system ensures precise sampler regulation in all configurations. Preselectors can be adapted for dust with pre-existing Air Flow-Puf samplers. It is also possible to change PM-HVS Air Flow samplers into TSP samplers with 150mm diameter filter holder supports.

PM-HVS Airflow High Volume Samplers are supplied complete with power cable, Italian language and English instructions manual, adjustable support holder for uneven surfaces, control bay locking system and NMI standard certificate of flow control. Software for memorised board data transfer and for later processing included in supply.

For further clarification on high volume sampler adapter kit see page 3 and 4 of this catalogue.

Expandability

It is possible to connect a weather sensor group to the sampler to simultaneously detect wind speed and direction. This option allows for sampling in origin quadrant sectors, therefore allowing the user to dedicate sampling solely to the sector of interest. Sampling starting will be constrained by wind speed and direction. Start parameters can be set directly by the user.

Technical Specifications	
External sampler structure	Non-corrosive anodized aluminium
Class of insulation	IP55
Sampling flow	200-1300 litres/ minute
Filter type	Rectangular 8x10 for PM 10 as per EN-12341
Flow control	Electronic with Venturi ISO 5167 device
Suction pump	Three-stage magnetic induction blower
Power	220 Volt/50 Hz
Absorption (Ampere)	15 at start / 4 during operating phases
Dimensions	120x37x37 cm (hxlxp)
Weight	13,0 Kg
CE Conformity	For electrical and electromagnetic safety
Maximum noise	65 dB in standard operating conditions

How to order	
600/AFPM1001K	Air Flow Sampler PM10-HVS (EN-12341)
600/GRMET001K	Weather sensor group with assembly kit
600/AFPUF1001GSM	GSM interface module
TE-235	5-stage cascade impactor
TE-234	4-stage cascade impactor
FAN/MFQ203254	Quartz micro fiber filters 20x25mm (8x10 inch) box 25pcs
NFS/GF1-8X10-100	Glass Fiber Filter Grade GF1 (Eq.GFA) 20x25 (8x10 inch)/100
FAN/MFQ150143SLT	Slotted Collection Substrates Quartz (25 per box) HVS Impactor
FAN/GF150143SLT	Slotted Collection Substrates Glass Fiber (100 per box) HVS Impactor
TE-230-WH	Cellulose impactor filters, box 100pcs
TE-230-AL	Aluminium sheets for impactor, box 25pcs



AMS[®]
Analitica
Air Monitoring Systems

P.le Coralloni, 12 - 61122 Pesaro (PU) Italia
Phone +39 0721 26243 Fax: +39 0721 26285
www.amsanalitica.com info@amsanalitica.com

AMS Analitica srl
ISO 9001:2008
Quality management system certified

ISO 9001
BUREAU VERITAS
Certification



Authorized Distributor in Pakistan

LABTECH
Tel: 042-36677186-88, 0300-3000347
Email: info@labtech-me.com
Website: www.labtech-me.com